

Product Specification

2.5Gbps BIDI SFP Optical Transceiver, 60Km

☑ Feature:

- SFP package with LC connector
- 1490nm DFB Laser and 1550nm PIN photodetector
- 1550nm DFB Laser and 1490nm PIN photodetector
- Up to 60Km transmission on SMF
- +3.3V single power supply
- LVPECL compatible data input/output interface
- Low EMI and excellent ESD protection
- laser safety standard IEC-60825 compliant
- Compatible with RoHS

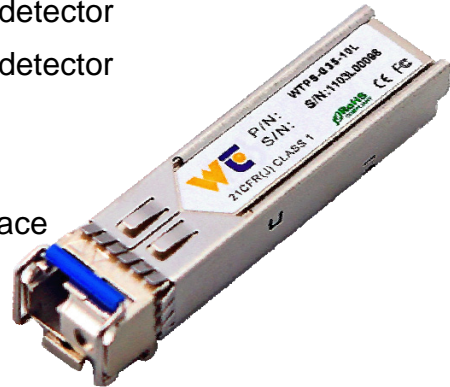

☑ Application

- Ethernet
- Telecom
- Fiber Channel

☑ Absolute Maximum Ratings

Parameter	Symbol	Minimum	Maximum	Units
Storage Temperature	Tst	0	+70	°C
Supply Voltage	Vcc	0	+3.6	V
Operating Relative Humidity	RH	5	95	%

Shenzhen **Wintop** Optical Technology Co., Ltd.

Address: 6/f, Bldg. 1, Sec. 3, South area, Honghualing Industrial
Zone Xili Town, Nanshan District, Shenzhen China
Web: www.wintoptec.com

Tel: +86 - 755- 2664 1737
Fax: +86- 755- 2664 0197
Email: sales@wintoptec.com

☑ Operation Environment

Parameter		Symbol	Min	Typical	Max	Units
Supply Voltage		V _{cc}	3.15	3.3	3.45	V
Operating Case Temperature	Commercial	T _c	-10		+70	°C
	Industrial		-40		+85	
Power Dissipation					1	W
Data Rate				2.5		Gbps

☑ Optical Characteristics

(Ambient Operating Temperature 0°C to +70°C, V_{cc} = 3.3 V)

Parameter		Symbol	Min.	Typ.	Max.	Units
Transmitter Section						
Center Wavelength	Tx 1490	λ_o	1470	1490	1510	nm
	Tx 1550		1530	1550	1570	
Spectral Width(RMS)	Tx 1490	$\Delta\lambda$	-	-	1	nm
	Tx 1550				1	
Average Output Power	Tx 1490	P _o	0	-	5	dBm
	Tx 1550		0		5	
Extinction Ratio		Er	9	-	-	dB
Rise/Fall Time(20%~80%)		Tr/Tf			0.26	ns
Total jitter		Tj			0.43	UI
Optical Eye Diagram		IEEE 802.3z and ANSI Fibre Channel Compatible				
Receiver Section						
Center Wavelength	Rx 1550	λ_o	1530	1550	1570	nm
	Rx 1490		1470	1490	1510	
Receiver Sensitivity		R _{sen}			-25	dBm
Receiver Overload		R _{ov}	-3			dBm
Return Loss			12			dB
LOS Assert		LOS _A	-30			dBm
LOS Dessert		LOS _D			-28	dBm
LOS Hysteresis			0.5		4	

Shenzhen **Wintop** Optical Technology Co., Ltd.

Address: 6/f, Bldg. 1, Sec. 3, South area, Honghualing Industrial Zone Xili Town, Nanshan District, Shenzhen China
 Web: www.wintoptec.com

Tel: +86 - 755- 2664 1737
 Fax: +86- 755- 2664 0197
 Email: sales@wintoptec.com

☑ Electrical Characteristics

(Ambient Operating Temperature 0°C to +70°C, Vcc =3.3 V)

Parameter	Symbol	Min.	Typ.	Max.	unit
Transmitter Section					
Input Differential Impedence	Zin	90	100	110	Ohm
Data Input Swing Differential	Vin	500		2400	mV
TX Disable	Disable		2.0	Vcc	V
	Enable		0	0.8	V
TX Fault	Assert		2.0	Vcc	V
	Deassert		0	0.8	V
Receiver Section					
Output differential impedance	Zout		100		Ohm
Data Input Swing Differential	Vout	370		2000	mV
Rx_LOS	Assert		2.0	Vcc	V
	Deassert		0	0.8	V

☑ EEPROM INFORMATION (A0) :

Addr	Field Size (Bytes)	Name of Field	HEX	Description
0	1	Identifier	03	SFP
1	1	Ext. Identifier	04	MOD4
2	1	Connector	07	LC
3-10	8	Transceiver	00 00 00 02 12 00 0D 01	Transmitter Code
11	1	Encoding	01	8B10B
12	1	BR, nominal	19	2500M bps
13	1	Reserved	00	
14	1	Length (9um)-km	50	40km
15	1	Length (9um)	64	
16	1	Length (50um)	00	
17	1	Length (62.5um)	00	
18	1	Length (copper)	00	
19	1	Reserved	00	
20-35	16	Vendor name	57 49 4E 54 4F 50 20 20 20 20 20 20 20 20 20 20	WINTOP
36	1	Reserved	00	
37-39	3	Vendor OUI	00 00 00	
40-55	16	Vendor PN	xx xx xx xx xx xx xx xx xx xx xx xx xx xx xx xx	ASC II
56-59	4	Vendor rev	31 2E 30 20	V1.0
60-61	2	Wavelength	05 D2E/06 0E	1480nm/1510nm
62	1	Reserved	00	
63	1	CC BASE	XX	Check sum of byte 0~62
64-65	2	Options	00 1A	LOS, TX_DISABLE, TX_FAULT
66	1	BR, max	32	50%
67	1	BR, min	32	50%
68-83	16	Vendor SN	00 00 00 00 00 00 00 00 00 00 00 00 00 00 00 00	Unspecified
84-91	8	Vendor date code	XX XX XX 20	Year, Month, Day
92-94	3	Reserved	00	
95	1	CC_EXT	XX	Check sum of byte 64~94
96-255	160	Vendor specific		

☑ Pin Description:

Pins	Name	Description	NOTE
1	VeeT	Transmitter Ground	
2	Tx Fault	Transmitter Fault Indication	1
3	Tx Disable	Transmitter Disable	2
4	MOD DEF2	Module Definition 2	3
5	MOD DEF1	Module Definition 1	3
6	MOD DEF0	Module Definition 0	3
7	Rate Select	Not Connected	
8	LOS	Loss of Signal	4
9	VeeR	Receiver Ground	
10	VeeR	Receiver Ground	
11	VeeR	Receiver Ground	
12	RD-	Inv. Received Data Output	5
13	RD+	IReceived Data Output	5
14	VeeR	Receiver Ground	
15	VccR	Receiver Power	
16	VccT	Transmitter Power	
17	VeeT	Transmitter Ground	
18	TD+	Transmit Data Input	6
19	TD-	Inv. Transmit Data Input	6
20	VeeT	Transmitter Ground	

Notes:

- TX Fault is an open collector output, which should be pulled up with a 4.7k~10k Ω resistor on the host board to a voltage between 2.0V and Vcc+0.3V. Logic 0 indicates normal operation; logic 1 indicates a laser fault of some kind. In the low state, the output will be pulled to less than 0.8V.
- TX Disable is an input that is used to shut down the transmitter optical output. It is pulled up within the module with a 4.7k~10k Ω resistor. Its states are:
 Low (0~0.8V): Transmitter on
 (>0.8V, <2.0V): Undefined
 High (2.0~3.3V): Transmitter Disabled
 Open: Transmitter Disabled
- MOD-DEF 0,1,2 are the module definition pins. They should be pulled up with a 4.7k~10k Ω resistor on the host board. The pull-up voltage shall be VccT or VccR.
 MOD-DEF 0 is grounded by the module to indicate that the module is present
 MOD-DEF 1 is the clock line of two wire serial interface for serial ID
 MOD-DEF 2 is the data line of two wire serial interface for serial ID
- LOS is an open collector output, which should be pulled up with a 4.7k~10k Ω resistor on the host board to a voltage between 2.0V and Vcc+0.3V. Logic 0 indicates normal operation; logic 1 indicates loss of signal. In the low state, the output will be pulled to less than 0.8V.
- These are the differential receiver output. They are internally AC-coupled 100 Ω differential lines which should be terminated with 100 Ω (differential) at the user SERDES.
- These are the differential transmitter inputs. They are AC-coupled, differential lines with 100 Ω differential termination inside the module.

Shenzhen *Wintop* Optical Technology Co., Ltd.

Address: 6/f, Bldg. 1, Sec. 3, South area, Honghualing Industrial
 Zone Xili Town, Nanshan District, Shenzhen China
 Web: www.wintoptec.com

Tel: +86 - 755- 2664 1737
 Fax: +86- 755- 2664 0197
 Email: sales@wintoptec.com

☑ Recommended Application Circuit

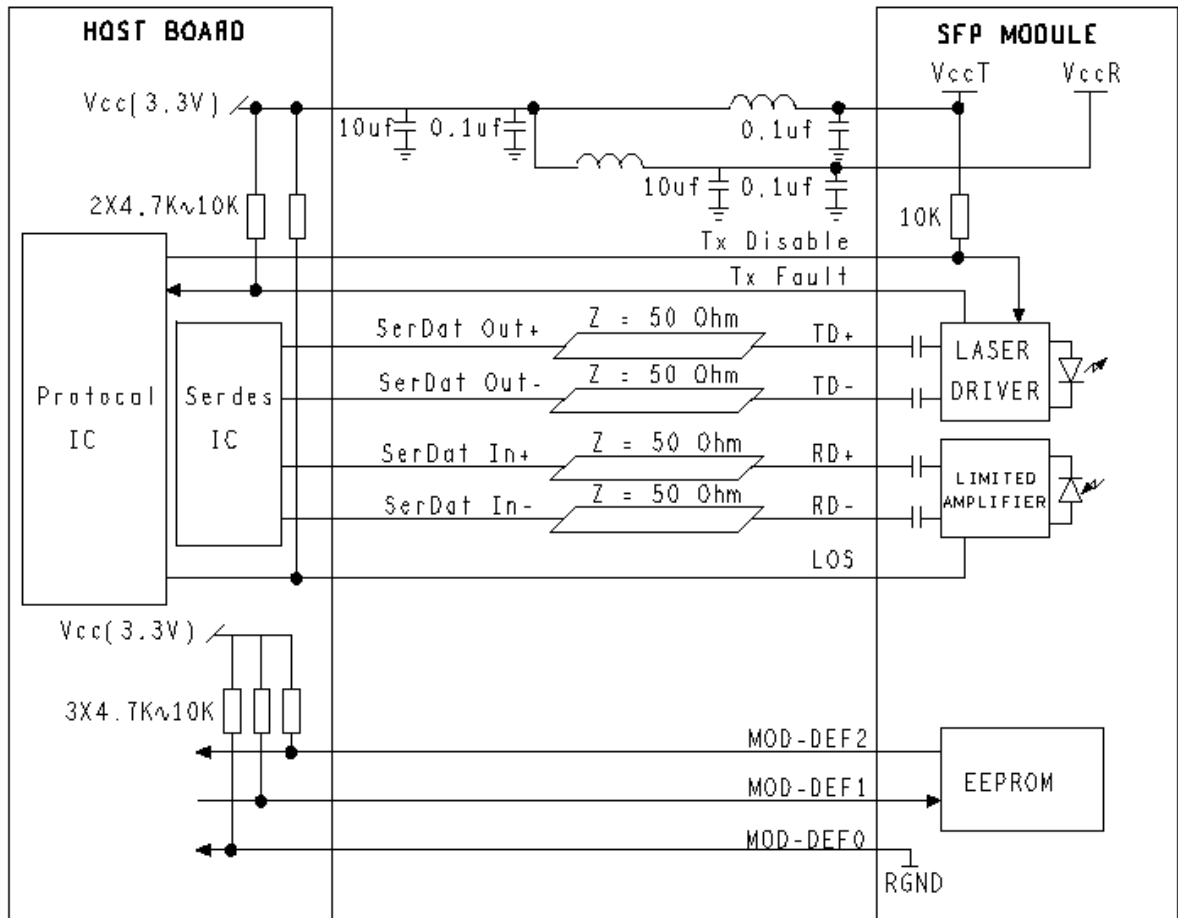

Shenzhen **Wintop** Optical Technology Co., Ltd.

Address: 6/f, Bldg. 1, Sec. 3, South area, Honghualing Industrial
Zone Xili Town, Nanshan District, Shenzhen China
Web: www.wintoptec.com

Tel: +86-755-2664 1737
Fax: +86-755-2664 0197
Email: sales@wintoptec.com

Outline drawing (mm):

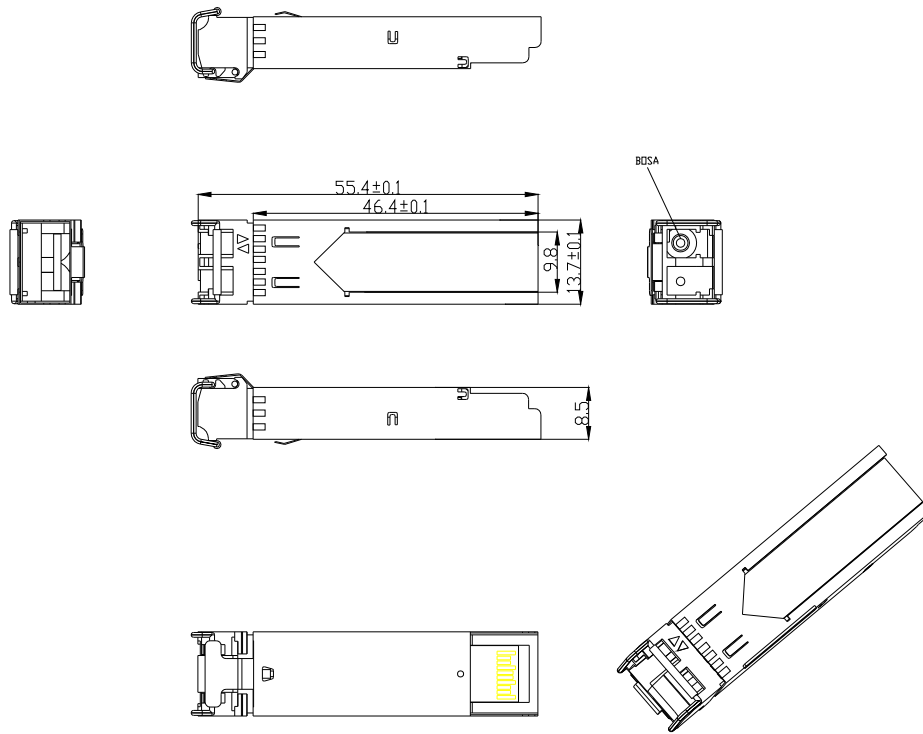

Ordering information :

WTPS-H45-60L	Commercial	0~70°C
WTPS-H45-60LI	Industrial	-40~85°C
WTPS-H54-60L	Commercial	0~70°C
WTPS-H54-60LI	Industrial	-40~85°C