



## 10Gb/s 850nm SFP+ Transceiver

### WT-SFP+-SR

#### Feature:

- SFP+ package with LC connector
- 850nm VCSEL Laser and PIN photo detector
- Up to 300m transmission on 2000MHz-km MMF
- Power dissipation < 1W
- LVPECL compatible data input/output interface
- Low EMI and excellent ESD protection
- laser safety standard IEC-60825 compliant
- Compatible with RoHS
- Compatible with SFF8472



#### Application

- Ethernet
- Fiber Channel

#### Absolute Maximum Ratings

| Parameter                   | Symbol | Minimum | Maximum | Units |
|-----------------------------|--------|---------|---------|-------|
| Storage Temperature         | Tst    | -40     | +85     | °C    |
| Supply Voltage              | Vcc    | 0       | +3.6    | V     |
| Operating Relative Humidity | RH     | 0       | 85      | %     |

#### Operation Environment

| Parameter                  | Symbol | Min  | Typical | Max  | Units |
|----------------------------|--------|------|---------|------|-------|
| Supply Voltage             | Vcc    | 3.15 |         | 3.45 | V     |
| Operating Case Temperature | Tc     | 0    |         | +70  | °C    |
| Power Dissipation          |        |      |         | 1    | W     |
| Data Rate                  |        |      | 10.3125 |      | Gbps  |



## Optical Characteristics

(Ambient Operating Temperature 0°C to +70°C, Vcc =3.3 V)

| Parameter                  | Symbol                | Min.         | Typ. | Max.  | Units |
|----------------------------|-----------------------|--------------|------|-------|-------|
| <b>Transmitter Section</b> |                       |              |      |       |       |
| Center Wavelength          | $\lambda_o$           | 840          | 850  | 860   | nm    |
| RMS Spectral Width         | $\Delta\lambda$       | -            | -    | 0.45  | dB    |
| Average Output Power       | Po                    | -5           | -    | -1    | dBm   |
| Extinction Ratio           | Er                    | 3.0          | -    | -     | dB    |
| Dispersion Penalty         |                       |              |      | 3.9   | dB    |
| Relative Intensity Noise   | RIN <sub>12</sub> OMA |              |      | -128  | dB/Hz |
| Total jitter               | Tj                    | IEEE 802.3ae |      |       |       |
| <b>Receiver Section</b>    |                       |              |      |       |       |
| Center Wavelength          | $\lambda_o$           |              | 850  |       | nm    |
| Receiver Sensitivity       | Rsen                  |              |      | -11.5 | dBm   |
| Stressed Sensitivity       | Rsen                  |              |      | -7.5  | dBm   |
| Receiver Overload          | Rov                   | 0            |      |       | dBm   |
| Return Loss                |                       | 12           |      |       | dB    |
| LOS Assert                 | LOS <sub>A</sub>      | -25          |      |       | dBm   |
| LOS Dessert                | LOS <sub>D</sub>      |              |      | -15   | dBm   |
| LOS Hysteresis             |                       | 0.5          |      | 4     |       |



## Electrical Characteristics

(Ambient Operating Temperature 0°C to +70°C, Vcc =3.3 V)

| Parameter                      | Symbol   | Min. | Typ. | Max. | unit |
|--------------------------------|----------|------|------|------|------|
| <b>Transmitter Section</b>     |          |      |      |      |      |
| Input Differential Impedence   | Zin      | 90   | 100  | 110  | Ohm  |
| Data Input Swing Differential  | Vin      | 180  |      | 700  | mV   |
| TX Disable                     | Disable  | 2.0  |      | Vcc  | V    |
|                                | Enable   | 0    |      | 0.8  | V    |
| TX Fault                       | Assert   | 2.0  |      | Vcc  | V    |
|                                | Deassert | 0    |      | 0.8  | V    |
| <b>Receiver Section</b>        |          |      |      |      |      |
| Output differential impedance  | Zout     |      | 100  |      | Ohm  |
| Data output Swing Differential | Vout     | 300  |      | 800  | mV   |
| Rx_LOS                         | Assert   | 2.0  |      | Vcc  | V    |
|                                | Deassert | 0    |      | 0.8  | V    |

## Maximum Supported Distances

| Parameter  | Symbol              | Min. | Typ. | Max. | unit |
|------------|---------------------|------|------|------|------|
| Fiber Type | 850nm OFL BandWidth |      |      |      |      |
| 62.5 um    | 160MHz-km           |      |      | 26   | m    |
|            | 200MHz-km           |      |      | 33   | m    |
| 50 um      | 400MHz-km           |      |      | 66   | m    |
|            | 500MHz-km           |      |      | 82   | m    |
|            | 2000MHz-km          |      |      | 300  | m    |



## Diagnostics

| Parameter    | Range   | Accuracy | Unit               | Calibration |
|--------------|---------|----------|--------------------|-------------|
| Temperature  | -5 ~ 75 | $\pm 3$  | $^{\circ}\text{C}$ | Internal    |
| Voltage      | 0 ~ VCC | 0.1      | V                  | Internal    |
| Bias Current | 0 ~ 12  | 0.3      | mA                 | Internal    |
| Tx Power     | -8 ~ 1  | $\pm 1$  | dBm                | Internal    |
| Rx Power     | -18 ~ 0 | $\pm 1$  | dBm                | Internal    |



EEPROM INFORMATION (A0) :

| Addr   | Field Size (Bytes) | Name of Field    | HEX  | Description                  |
|--------|--------------------|------------------|--|------------------------------|
| 0      | 1                  | Identifier       | 03   | SFP                          |
| 1      | 1                  | Ext. Identifier  | 04   | MOD4                         |
| 2      | 1                  | Connector        | 07   | LC                           |
| 3-10   | 8                  | Transceiver      | 10 00 00 00 00 00 00 00                            | Transmitter Code             |
| 11     | 1                  | Encoding         | 06   | 64B66B                       |
| 12     | 1                  | BR, nominal      | 67   | 10000M bps                   |
| 13     | 1                  | Reserved         | 00   |                              |
| 14     | 1                  | Length (9um)-km  | 00   |                              |
| 15     | 1                  | Length (9um)     | 00   |                              |
| 16     | 1                  | Length (50um)    | 08   |                              |
| 17     | 1                  | Length (62.5um)  | 02   |                              |
| 18     | 1                  | Length (copper)  | 00   |                              |
| 19     | 1                  | Reserved         | 00   |                              |
| 20-35  | 16                 | Vendor name      | 57 49 4E 54 4F 50 20 20<br>20 20 20 20 20 20 20 20 | WINTOP                       |
| 36     | 1                  | Reserved         | 00   |                              |
| 37-39  | 3                  | Vendor OUI       | 00 00 00   |                              |
| 40-55  | 16                 | Vendor PN        | xx xx xx xx xx xx xx xx<br>xx xx xx xx xx xx xx xx | ASC II                       |
| 56-59  | 4                  | Vendor rev       | 31 2E 30 20  | V1.0                         |
| 60-61  | 2                  | Wavelength       | 03 52  | 850nm                        |
| 62     | 1                  | Reserved         | 00   |                              |
| 63     | 1                  | CC BASE          | XX   | Check sum of byte 0~62       |
| 64-65  | 2                  | Options          | 00 1A  | LOS, TX_DISABLE,<br>TX_FAULT |
| 66     | 1                  | BR, max          | 00   |                              |
| 67     | 1                  | BR, min          | 00   |                              |
| 68-83  | 16                 | Vendor SN        | 00 00 00 00 00 00 00 00<br>00 00 00 00 00 00 00 00 | Unspecified                  |
| 84-91  | 8                  | Vendor date code | XX XX XX 20  | Year, Month, Day             |
| 92-94  | 3                  | Reserved         | 00   |                              |
| 95     | 1                  | CC_EXT           | XX   | Check sum of byte 64~94      |
| 96-255 | 160                | Vendor specific  |  |                              |



## Pin Description:

| Pins | Name       | Description                  | NOTE |
|------|------------|------------------------------|------|
| 1    | VeeT       | Transmitter Ground           |      |
| 2    | Tx Fault   | Transmitter Fault Indication | 1    |
| 3    | Tx Disable | Transmitter Disable          | 2    |
| 4    | MOD DEF2   | Module Definition 2          | 3    |
| 5    | MOD DEF1   | Module Definition 1          | 3    |
| 6    | MOD DEF0   | Module Definition 0          | 3    |
| 7    | RS0        | Not Connected                |      |
| 8    | LOS        | Loss of Signal               | 4    |
| 9    | RS1        | Not Connected                |      |
| 10   | VeeR       | Receiver Ground              |      |
| 11   | VeeR       | Receiver Ground              |      |
| 12   | RD-        | Inv. Received Data Output    | 5    |
| 13   | RD+        | IReceived Data Output        | 5    |
| 14   | VeeR       | Receiver Ground              |      |
| 15   | VccR       | Receiver Power               |      |
| 16   | VccT       | Transmitter Power            |      |
| 17   | VeeT       | Transmitter Ground           |      |
| 18   | TD+        | Transmit Data Input          | 6    |
| 19   | TD-        | Inv. Transmit Data Input     | 6    |
| 20   | VeeT       | Transmitter Ground           |      |

### Notes:

1. TX Fault is an open collector output, which should be pulled up with a 4.7k~10k  $\Omega$  resistor on the host board to a voltage between 2.0V and Vcc+0.3V. Logic 0 indicates normal operation; logic 1 indicates a laser fault of some kind. In the low state, the output will be pulled to less than 0.8V.
2. TX Disable is an input that is used to shut down the transmitter optical output. It is pulled up within the module with a 4.7k~10k  $\Omega$  resistor. Its states are:  
Low (0~0.8V): Transmitter on  
(>0.8V, <2.0V): Undefined  
High (2.0~3.465V): Transmitter Disabled  
Open: Transmitter Disabled
3. MOD-DEF 0,1,2 are the module definition pins. They should be pulled up with a 4.7k~10k  $\Omega$  resistor on the host board. The pull-up voltage shall be VccT or VccR.  
MOD-DEF 0 is grounded by the module to indicate that the module is present  
MOD-DEF 1 is the clock line of two wire serial interface for serial ID  
MOD-DEF 2 is the data line of two wire serial interface for serial ID
4. LOS is an open collector output, which should be pulled up with a 4.7k~10k  $\Omega$  resistor on the host board to a voltage between 2.0V and Vcc+0.3V. Logic 0 indicates normal operation; logic 1 indicates loss of signal. In the low state, the output will be pulled to less than 0.8V.
5. These are the differential receiver output. They are internally AC-coupled 100 $\Omega$  differential lines which should be terminated with 100 $\Omega$  (differential) at the user SERDES.



6. These are the differential transmitter inputs. They are AC-coupled, differential lines with 100Ω differential termination inside the module.

## Recommended Application Circuit

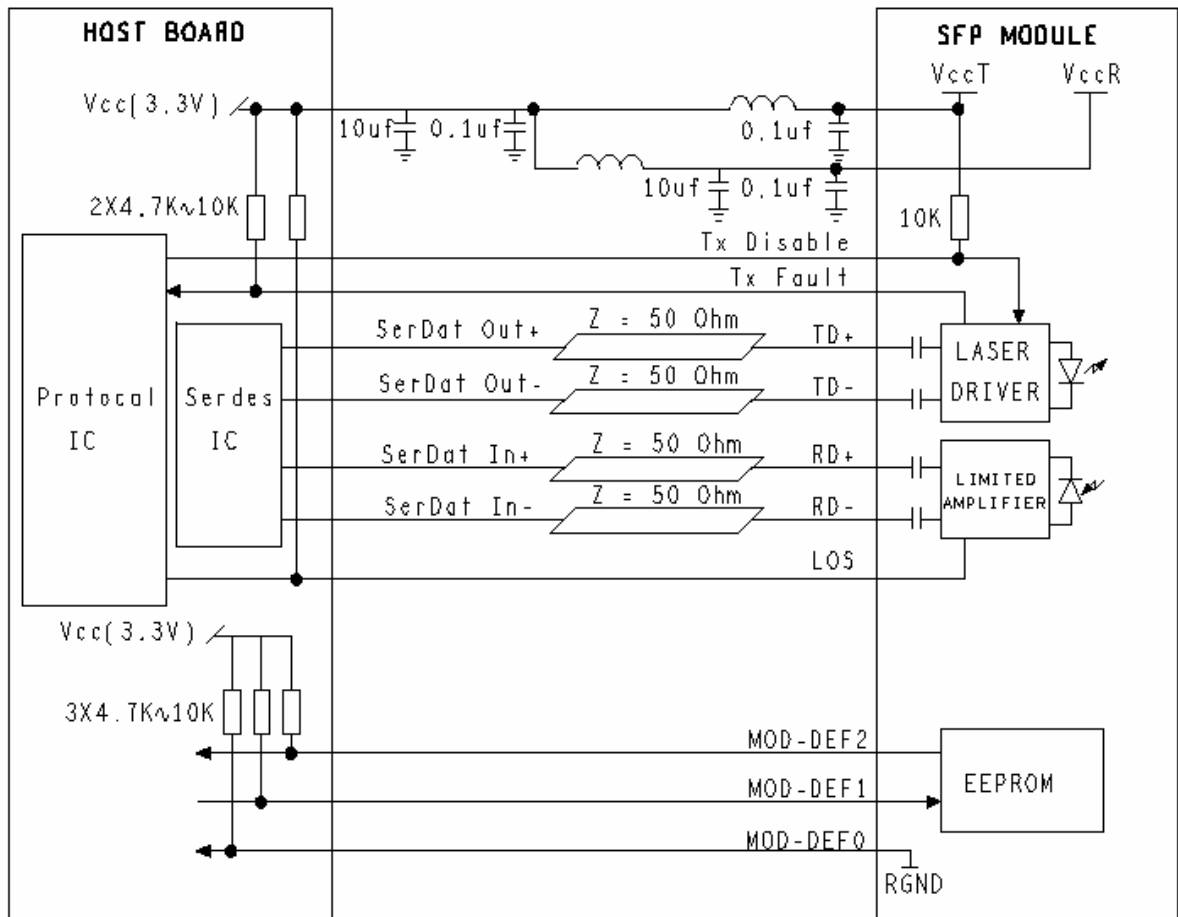



**Outline drawing (mm):**

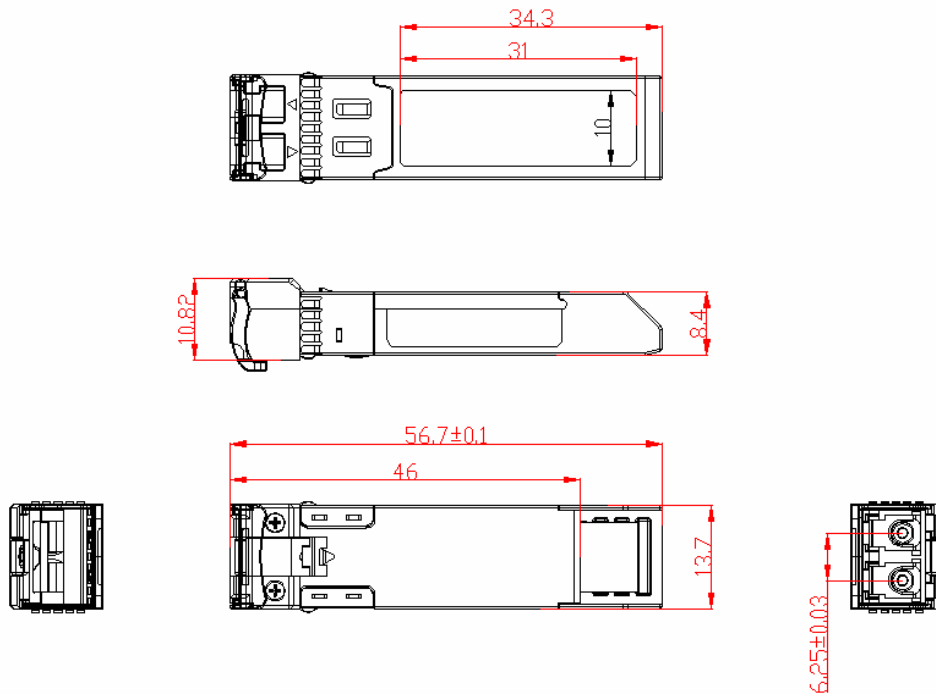

**Ordering information :**

|            |            |        |
|------------|------------|--------|
| WT-SFP+-SR | Commercial | 0~70°C |
|------------|------------|--------|

**Contact :**

|         |  |
|---------|--|
| Address | 6/f, Bldg. 1, Sec. 3, South area, Honghualing Industrial Zone<br>Xili Town, Nanshan District, Shenzhen China |
| Zip     | 518054   |
| Tel     | 086-26641737   |
| Fax     | 086-0755-26640197  |
| Website | www.wintoptec.com  |